

1) Introduction

The BExTBG05D is a flameproof Flashtel which is certified to meet the requirements of the ATEX directive 94/9/EC and IECEx scheme. The Flashtel produces a visual warning signal when triggered by a telephone ringing signal and can be used in hazardous areas where potentially flammable gas and dust atmospheres may be present. The BExTBG05D has a flash energy level of 5 joules and can be used in Zone 1 and Zone 2 areas with gases in groups IIA, IIB and IIC and Temperature Classifications of T1, T2, T3 and T4. The unit can also be used in a temperature classification T5, if the upper ambient temperature is restricted to +55°C and T6 if the upper ambient temperature is restricted to +40°C. The unit can be used in Zone 21 and Zone 22 areas for combustible dusts and has an IP rating of IP 67 and a surface temperature rating of T110°C or T95°C if the upper ambient temperature is restricted to +55°C and T85°C if the upper ambient temperature is restricted to +40°C.

2) Marking

All units have a rating label, which carries the following important information:-

Unit Type No. BExTBG05D

Input Voltage: 230V or 115V

Codes: Ex d IIC T4 for Ta -50°C to +70°C
 Ex d IIC T5 for Ta -50°C to +55°C
 Ex d IIC T6 for Ta -50°C to +40°C
 Ex tD A21 IP67 T115°C based on max. Ta of +70°C

Certificate No's KEMA 00ATEX2006
 IECEx KEM 10.0002

Epsilon x
 Equipment Group and
 Category:



II 2G/D

CE Marking
 Notified Body No.



0518

“Warnings” DO NOT OPEN WHEN AN EXPLOSIVE
 GAS OR DUST ATMOSPHERE IS PRESENT

COVER BOLTS CLASS A4-80

USE HEAT RESISTING CABLES AND CABLE GLANDS
 (Rated 110°C) AT AMB. TEMPERATURES OVER 40°C

Year of Construction /

Serial No. i.e. 10 / 1DTB1300001

3) Type Approval Standards

The Flashtel has EC Type Examination and IECEx certificates issued by KEMA and has been approved to the following standards:-

EN60079-0:2006	IEC60079-0:2004 (Ed4)	General Requirements
EN60079-1:2007	IEC60079-1:2007 (Ed6)	Flameproof Enclosure 'd'
EN61241-0:2006	IEC61241-0:2004 (Ed1)	Dust General Requirements
EN61241-1:2004	IEC60079-1:2004 (Ed1)	Dust Enclosures tD

4) Installation Requirements

The Flashtel must be installed in accordance with the latest issues of the relevant parts of the EN60079 standards or the equivalent IEC standards – Selection, Installation and maintenance of electrical apparatus for use in potentially explosive atmospheres (other than mining applications or explosive processing and manufacture):-

EN60079-14:2008 Electrical Installations in Hazardous Areas (other than mines)
 IEC60079-14:2007 (Ed4)

EN60079-10:2003 Classification of Hazardous Areas
 IEC60079-10:2008 (Ed1)

The installation of the units must also be in accordance with any local codes that may apply and should only be carried out by a competent electrical engineer who has the necessary training.

5) Zones, Gas Group, Category, IP Rating and Temperature Classification

The BExTBG05D beacons have been certified Ex d IIC T4 for Ta -50°C to +70°C, Ex d IIC T5 for Ta -50°C to +55°C and Ex d IIC T6 for Ta -50°C to +40°C for gas and IP67 T115°C based on max. Ta of +70°C for dust. This means that the units can be installed in locations with the following conditions:-

Area Classification Gas:

Zone 1	Explosive gas air mixture likely to occur in normal operation.
Zone 2	Explosive gas air mixture not likely to occur, and if it does, it will only exist for a short time.

Gas Groupings:

Group IIA	Propane
Group IIB	Ethylene
Group IIC	Hydrogen and Acetylene

Temperature Classification:

T1	400°C
T2	300°C
T3	200°C
T4	135°C

T5	100°C	Amb. +55°C
T6	85°C	Amb. +40°C

Area Classification Dust:

Zone 21	Explosive dust air mixture likely to occur in normal operation.
Zone 22	Explosive dust air mixture not likely to occur, and if it does, it will only exist for a short time.

IP Rating: IP67 T110°C Ta ≤ +70°C
T95°C Ta ≤ +55°C
T85°C Ta ≤ +40°C

Equipment Category: 2G/D

Ambient Temperature Range: -50°C to +70°C
(T5 = +55°C)
(T6 = +40°C)

6) Flashtel Location and Mounting

The location of the Flashtel should be made with due regard to the area over which the signal must be visible. It should only be fixed to services that can carry the weight of the unit.

The Flashtel should be securely bolted to a suitable surface using the 7mm diameter boltholes in the stainless steel U shaped mounting bracket (see figure 1). The required angle can be achieved by loosening the two large bracket screws in the side of the unit, which allow adjustment of the beacon in steps of 18°. On completion of the installation the two large bracket adjustment screws on the side of the unit must be fully tightened to ensure that the unit cannot move in service.

SAFETY WARNING:

The flashdome guard must not be removed from the unit at any time.

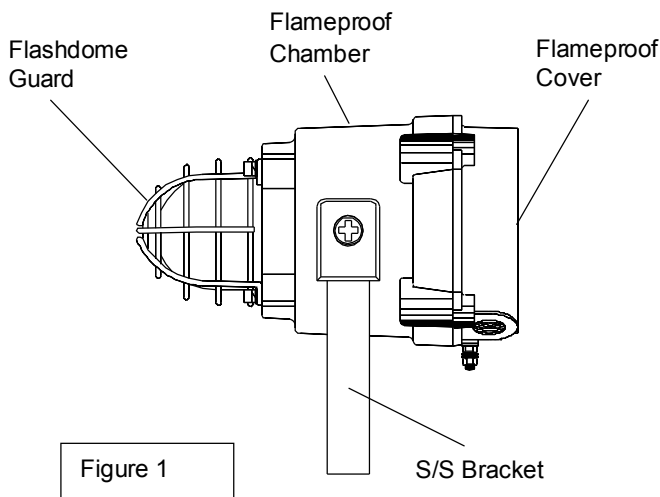

Figure 1

7) Access to the Flameproof Enclosure

In order to connect the electrical supply cable and the telephone line cable to the Flashtel it is necessary to remove the flameproof cover to gain access to the flameproof chamber. To achieve this remove the four M6 hexagon socket head screws (see figure 2) and withdraw the flameproof cover taking extreme care not to damage the flameproof joints in the process.

Note the four **M6 screws are Class A4-80 stainless steel and only screws of this category can be used on the**

Flashtel. It is therefore important that these screws and their spring washers are kept in a safe place during installation.

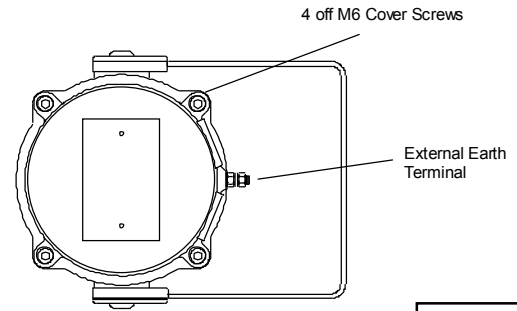

Figure 2

On completion of the cable wiring installation the flameproof joints should be inspected to ensure that they are clean and that they have not been damaged during installation. Also check that the earth bonding wire between the two casting sections is secure and the 'O' ring seal is in place. When replacing the flameproof cover casting ensure that it is square with the flameproof chamber casting before inserting. Carefully push the cover in place allowing time for the air to be expelled. Only after the cover is fully in place should the four M6 Stainless Steel A4-80 cover bolts and their spring washer be inserted and tightened down. If the cover jams while it is being inserted, carefully remove it and try again. Never use the cover bolts to force the cover into position.

8) Power Supply Selection

It is important that a suitable power supply is used to run the Flashtel. The following table shows the input current taken by the Flashtel:-

Unit Type	Nominal I/P Voltage	Input Current	Max. I/P
BExTBG05D	230V AC	55mA	253V
BExTBG05D	115V AC	140mA	126V

The input current will vary according to the voltage input level. The current levels shown above are for nominal input voltage.

The above table also shows the maximum voltages at which the Flashtel can be operated.

9) Cable Selection

SAFETY WARNING: If the BExTBG05D Flashtels are used at high ambient temperatures, i.e. over +40°C, then the cable entry temperature may exceed +70°C and therefore suitable heat resisting cables must be used, with a rated service temperature of at least 110°C.

BExTBG05D Flashtel Cover Internal View

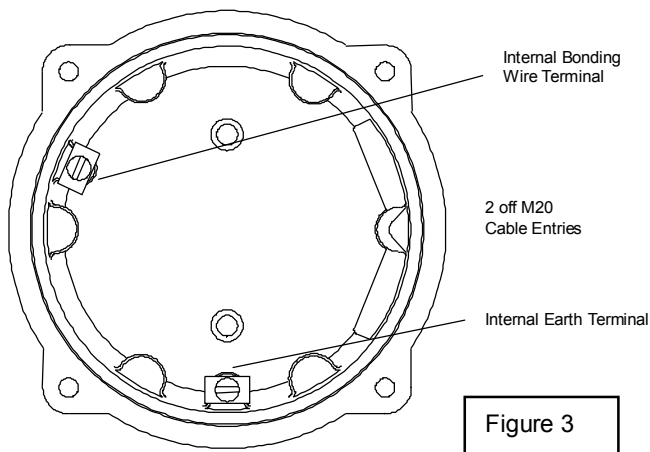

10) Earthing

The Flashtel unit must be connected to a good quality earth. The units are provided with internal and external earthing terminals which are both located on the terminal chamber section of the unit (see figures 2 and 3).

When using the internal earth terminal ensure that the stainless steel M4 flat washer is between the incoming earth wire and the enclosure.

When using the external earth terminal a cable crimp lug must be used. The cable lug should be located between the two M5 stainless steel flat washers. The M5 stainless steel spring washer must be fixed between the outer flat washer and the M5 stainless steel nut to ensure that the cable lug is secured against loosening and twisting.

The internal earth bonding wire ensures that a good quality earth is maintained between the flameproof chamber casting and the flameproof cover casting.

11) Cable Glands

The BExTBG05D Flashtels have dual cable gland entries which have an M20 x1.5 entry thread as standard (see cable connections section 12 of this manual). Only cable glands approved for Ex 'd' applications can be used, which must be suitable for the type of cable being used and also meet the requirements of the Ex 'd' flameproof installation standard EN60079-14:2008 / IEC60079-14:2007.

When only one cable entry is used the other one must be closed with an Ex 'd' flameproof blanking plug, which must be suitably approved for the installation requirements.

For combustible dust applications, the cable entry device and blanking elements shall be in type of explosion protection increased safety "e" or flameproof enclosure "d" and shall have an IP 6X rating according to EN60529:1992.

SAFETY WARNING: If the BExTBG05D Flashtels are used at high ambient temperatures, i.e. over +40°C, then the cable entry temperature may exceed +70°C and therefore suitable heat resisting cable glands must be used, with a rated service temperature of at least 110°C.

12) Cable Connections

The cable connections are made into the terminal blocks on the electronic pcb assembly located in the flameproof enclosure. See section 7 of this manual for access to the flameproof enclosure.

The printed circuit board has two terminal blocks, one for the mains supply input voltage and one for the telephone signal input cable (see figure 4). The mains input cable should enter the enclosure via one of the M20 cable entries and be connected to the supply terminals L and N and the telephone signal cable should enter the enclosure via the other M20 entry and be connected to the telephone terminal.

Wires having a cross sectional area of up to 4mm² can be connected to each terminal way. When connecting wires to the terminals great care should be taken to dress the wires so that when the cover is inserted into the chamber the wires do not exert excess pressure on the terminal blocks. This is particularly important when using cables with large cross sectional areas such as 2.5mm².

BExTBG05D 5 Joule Flashtel

